

The Windshear[®] TopShot

PROTO-VEST, INC.



- Touch-less
- Low Maintenance
- High Car Per Hour Count
- Compact Design
- 30hp Magnum Blower

Proto-Vest[®] Inc.

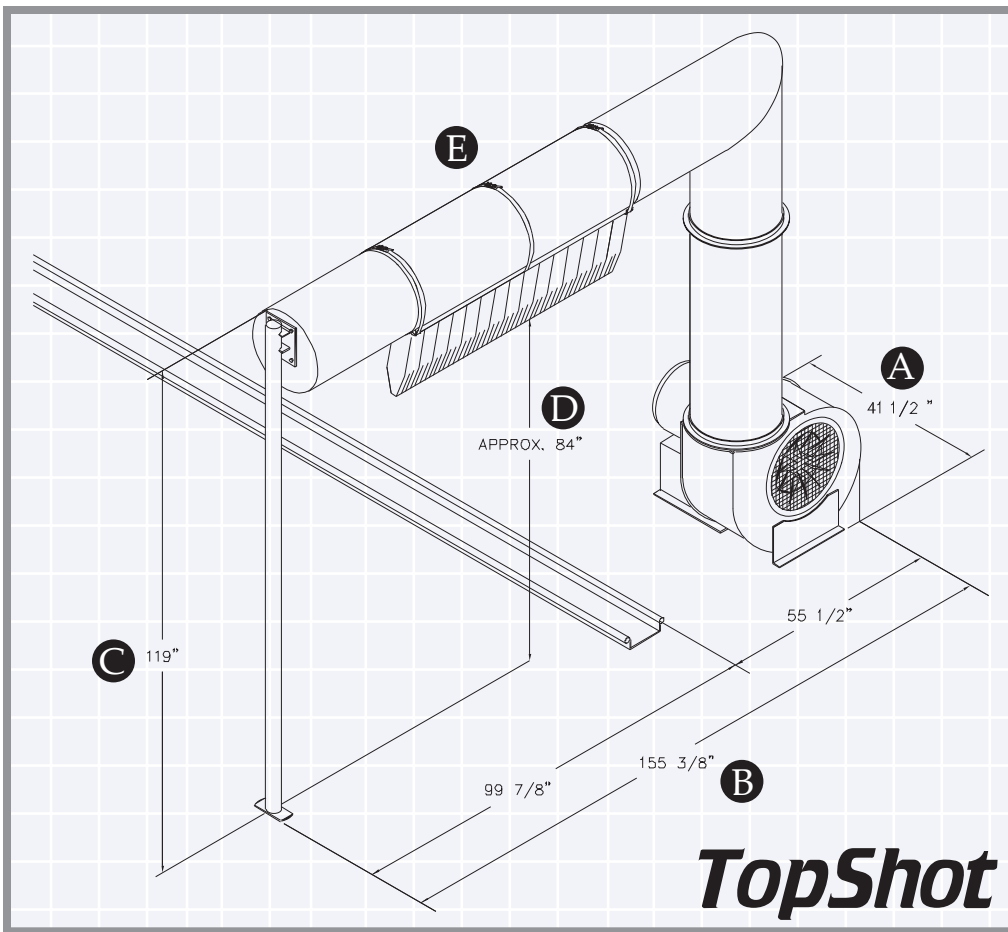

EQUIPMENT

- A** OVERALL LENGTH
41 1/2 in.
- B** OVERALL WIDTH
155 3/8 in.
- C** OVERALL HEIGHT
119 in.
- D** BAG HEIGHT
84 in.
- E** BAG WIDTH
60 in.

MOTORS

- 30 hp, 3600 RPM's
- 230 / 460 volts
- 1.15 service factor
- Frame: 286TS
- 3 Phase
- Fan-cooled, totally enclosed (TEFC)

NOTE: Wiring and controls to be provided by the purchaser: Additional motor specifications available upon request. Additional voltages available on special order.

EQUIPMENT OPTIONS

- Green, Red, Blue or Custom Bag Colors
- The Silencer Package
- Mist Eliminator
- Airgate

GENERAL DESCRIPTION

The Proto-Vest "TopShot" is designed as both a stand alone and modular drying system. It is ideal for tunnel operations with a variety of line speeds, roll-overs and self-service applications. This patented system utilizes one (1) 30-hp Magnum blower, plenum and a 60" Proto-Duck™ overhead bag designed to direct air around the vehicle as it passes under the equipment arch.

Proto-Vest's blower/motor assembly is engineered for both maximum efficiency and cost effectiveness. As an option, the equipment can be manufactured with Proto-Vest Silencer Package™ to reduce noise emanating from the blower/motor.

Proto-Vest's stringent standards in material selection for its dryers result in extended equipment life and reduced maintenance. The blower assembly is manufactured from steel that is powder coated and the blower is AMCA Class IV certified. The plenum is made from 5052-H32 aluminum while the bag is produced from durable Proto-Duck™ material which resists both corrosion and tearing.

FEATURES / BENEFITS

Patented Touchless Design:

Pressurized air flows through a patented bag which directs air to the vehicle's horizontal and vertical surface. It dries the hood, roof, deck and windows.

Low Maintenance:

Other than the blower/motor assembly, there are no moving parts to wear-out or break down.

(Please note that Proto-Vest recommends routine maintenance in order to maximize product life.)

Line Speed Efficiency:

As a stand alone unit the "TopShot" can effectively dry a car at a variety of line speeds.

Compact / Modular design:

Designed to fit into limited space as a stand alone or supplemental dryer.

DECIBEL READINGS

With Silencer / Without Silencer	
(WS)	(WOS)
TopShot - (1) 30hp dryer:	
WS: 10 ft=76.9 dBA;	WOS: 10 ft=91 dBA
WS: 20 ft=70.9 dBA;	WOS: 20 ft=84.9 dBA
WS: 30 ft=67.4 dBA;	WOS: 30 ft=81.4 dBA
WS: 40 ft=64.9 dBA;	WOS: 40 ft=78.9 dBA
WS: 50 ft=63 dBA;	WOS: 50 ft=77 dBA
(The above decibel readings are interpolated.)	

SERVICE / SUPPORT

Proto-Vest recognizes that support after the sale of equipment is critical to the success of our customers. Our company offers its customers access to a wide range of services including: field service technicians, factory direct aftermarket parts, and an engineering staff for custom designed applications.

Proto-Vest Patents:

U.S.: 3,942,430; 4,161,801; 4,409,035; 4,418,442; 4,433,450; 4,445,251; 4,446,592; 4,589,160; 4,700,426; 5,027,714; 5,184,369; 5,187,881; 5,195,207; 5,280,665; 5,421,102; 5,553,346; 5,886,648; 5,901,461; 5,950,324; 5,960,564; 6,038,781; 6,176,024; 6,519,872; others pending.

Canada: 1,021,996; 1,111,328; 1,190,453; 1,201,040; 1,197,439; 1,219,195; 1,219,192; 1,219,194; 1,258,026; 1,219,193; 2,013,749; 2,071,568; 2,071,239; 2,071,388; others pending.

Proto-Vest Inc.

*Specifications subject to change without notice.

**If starting motor over 10-12 times an hour it may be more efficient to leave blower on.

Proto-Vest, Inc., 7400 N. Glen Harbor Blvd., Glendale, AZ 85307 • 800-521-8218 • 623-872-8300 • Fax 623-872-6150
www.proto-vest.com

© Copyright 1998, Proto-Vest, Inc. All rights reserved.