

The Windshear[®] InBay RM

PROTO-VEST, INC.

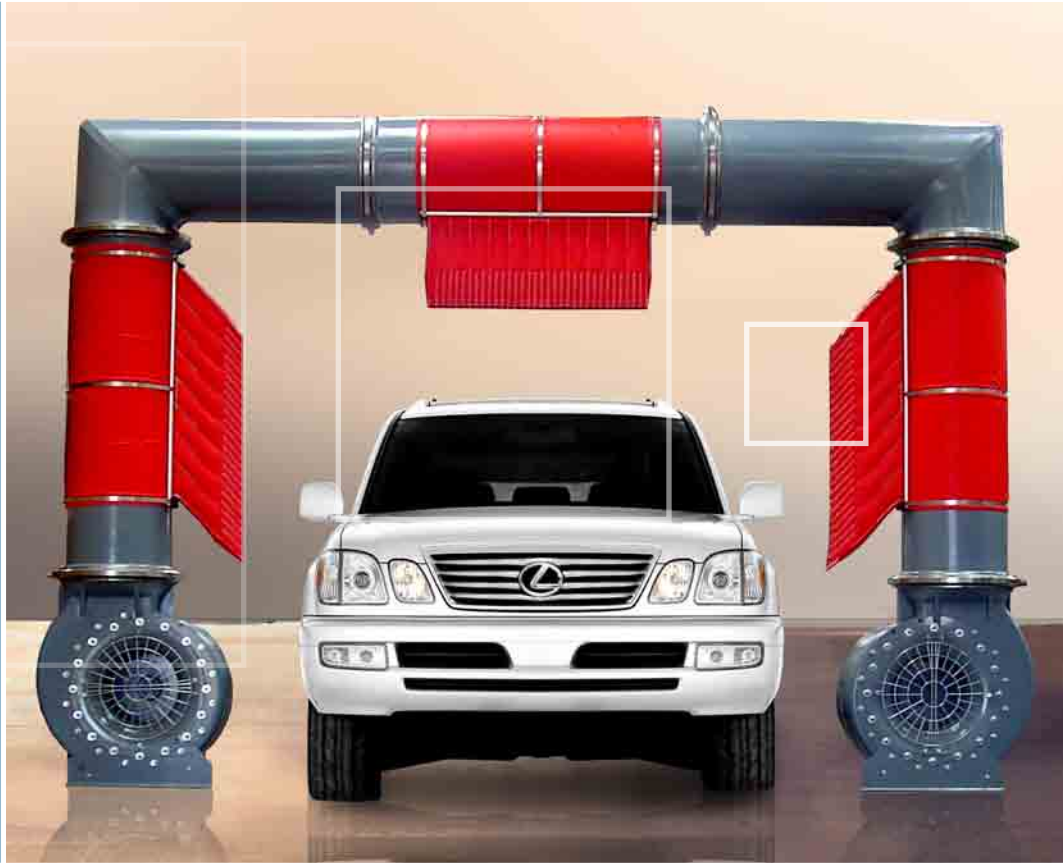

- **Dent Proof, Corrosion Proof And Easy To Assemble**
- **Touch-less**
- **Low Maintenance**
- **Reduced Drive Through Time**
- **(2) 25hp Blowers**

Proto-Vest[®] Inc.

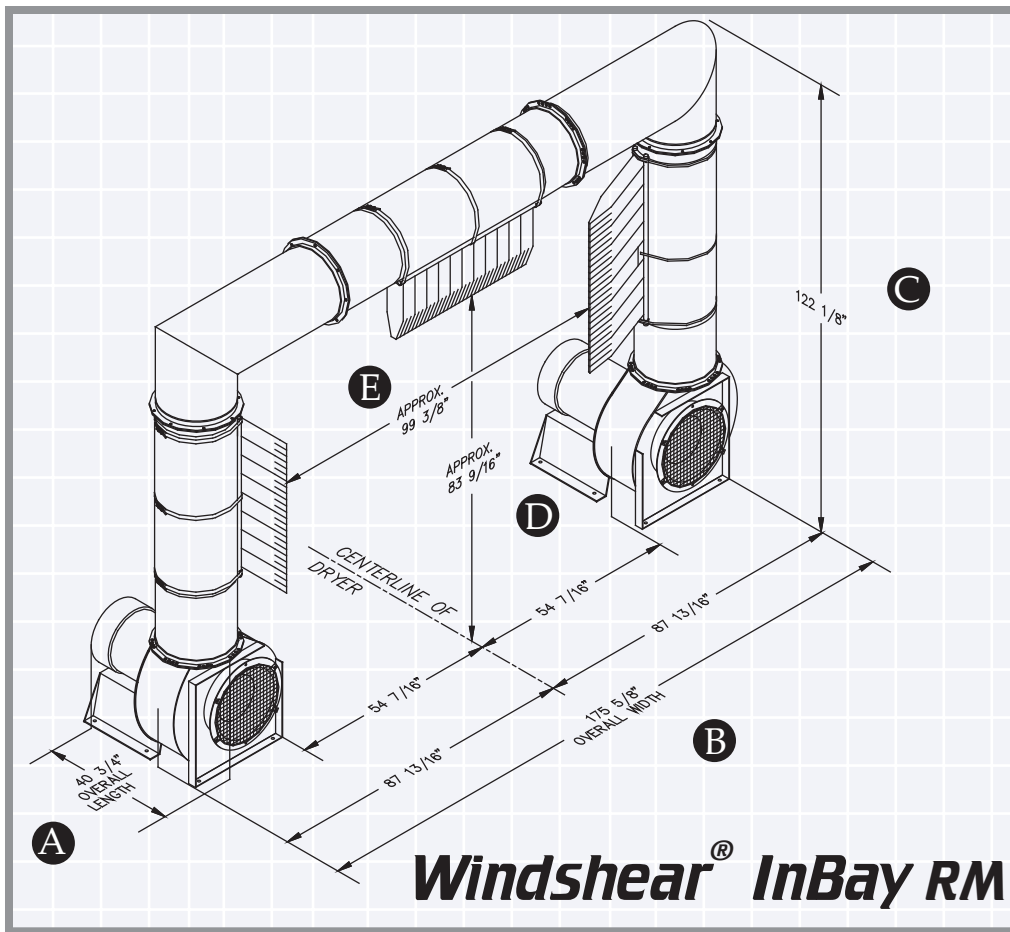

EQUIPMENT

- A** OVERALL LENGTH
40 3/4 in.
- B** OVERALL WIDTH
175 5/8 in.
- C** OVERALL HEIGHT
122 1/8 in.
- D** BAG HEIGHT
83 9/16 in.
- E** SIDE BAG SPACING
99 3/8 in. apart

MOTORS

- *(2) 25 hp, 3600 RPM
- 230 / 460 volts
- 1.15 service factor
- Frame: 284TS
- 3 Phase
- Totally enclosed, fan cooled (TEFC)

NOTE: Wiring and controls to be provided by the purchaser. Additional motor specifications available upon request. Additional voltages available on special order.

EQUIPMENT OPTIONS

- Raised Intake
- Green, Red, Blue or Custom Bag Colors
- The Airgate
- The Silencer Package™

Weight: 1496 lbs. (approximate)

GENERAL DESCRIPTION

The Windshear InBay RM dryer is a cost effective solution constructed from high-density polyethylene alloy, making it dent proof, corrosion proof and easy to assemble. Specifically designed for InBay applications this system utilizes two (2) 25-hp blowers and three (3) air delivery bags designed to direct air around the vehicle as it passes through the equipment. Each bag is fully adjustable in 5 degree increments from 0 to 15 degrees. In addition, the upper air deployment device is angled towards the rear of the vehicle to effectively dry the backend of Vans and SUVs! All bags are produced from durable Proto-Duck™ material, which resists corrosion and tearing.

Proto-Vest's stringent standards in material selection for dryers result in extended equipment life and reduced maintenance. The plenum is constructed from high-density polyethylene alloy while both the blower/motor assemblies are engineered for both maximum efficiency and cost effectiveness.

FEATURES / BENEFITS

Patented Touchless Design: Pressurized air flows through three (3) patented bags which direct the air to the vehicle's horizontal and vertical surfaces. It dries the hood, roof, deck, windows, and top side panels of the vehicle without touching.

Low Maintenance: High-density polyethylene alloy makes the InBay RM dent proof, corrosion proof and easy to assemble in under 30 minutes.

Other than the blower/impeller assemblies, there are no moving parts to wear-out or break down.

(Please note that Proto-Vest recommends routine maintenance in order to maximize product life.)

Compact / Modular engineering: Designed to fit into limited space as a stand alone dryer.

Drying performance is affected if any of the following are present: 1) If the car is not clean; 2) Use of RO water without drying agent; 3) If cleaning agents are not properly balanced; 4) Insufficient rinsing (soap on vehicle); 5) Inadequate balance between rinse water & drying agent; 6) Excessive drive through speed.

*Specifications subject to change without notice.

**For 208V applications it is HIGHLY RECOMMENDED to upgrade to 30hp motors

***If starting motor over 10-12 times an hour it may be more efficient to leave blower on.

DECIBEL READINGS

With Silencer / Without Silencer
(WS) (WOS)

Windshear® InBay RM - (2) 25hp dryers:

WS: 10 ft=88 dBa; WOS: 10 ft=94 dBa

WS: 20 ft=82 dBa; WOS: 20 ft=88 dBa

WS: 30 ft=78.4 dBa; WOS: 30 ft=84.5 dBa

WS: 40 ft=76 dBa; WOS: 40 ft=82 dBa

WS: 50 ft=74 dBa; WOS: 50 ft=80 dBa

WS: 60 ft=72.4 dBa; WOS: 60 ft=78.4 dBa

(The above decibel readings are interpolated.)

SERVICE / SUPPORT

Proto-Vest recognizes that support after the sale of equipment is critical to the success of our customers. Our company offers its customers access to a wide range of services including: field service technicians, factory direct aftermarket parts, and an engineering staff for custom designed applications.

Proto-Vest Patents:

U.S.: 3,942,430; 4,161,801; 4,409,035; 4,418,442; 4,433,450; 4,445,251; 4,446,592; 4,589,160; 4,700,426; 5,027,714; 5,184,369; 5,187,881; 5,195,207; 5,280,665; 5,421,102; 5,553,346; 5,886,648; 5,901,461; 5,950,324; 5,960,564; 6,038,781; 6,176,024; 6,519,872; others pending.

Canada: 1,021,996; 1,111,328; 1,190,453; 1,201,040; 1,197,439; 1,219,195; 1,219,192; 1,219,194; 1,258,026; 1,219,193; 2,013,749; 2,071,568; 2,071,239; 2,071,388; others pending.

Proto-Vest Inc.

Proto-Vest, Inc., 7400 N. Glen Harbor Blvd., Glendale, AZ 85307 • 800-521-8218 • 623-872-8300 • Fax 623-872-6150
www.proto-vest.com

© Copyright 1998, Proto-Vest, Inc. All rights reserved.