

**The Stripper**

**90N**



- Minimal Decibel Level
- Low Maintenance
- High Vehicle Count Per Hour
- Patented Design
- 15hp Blower

**Proto-Vest Inc.**<sup>®</sup>

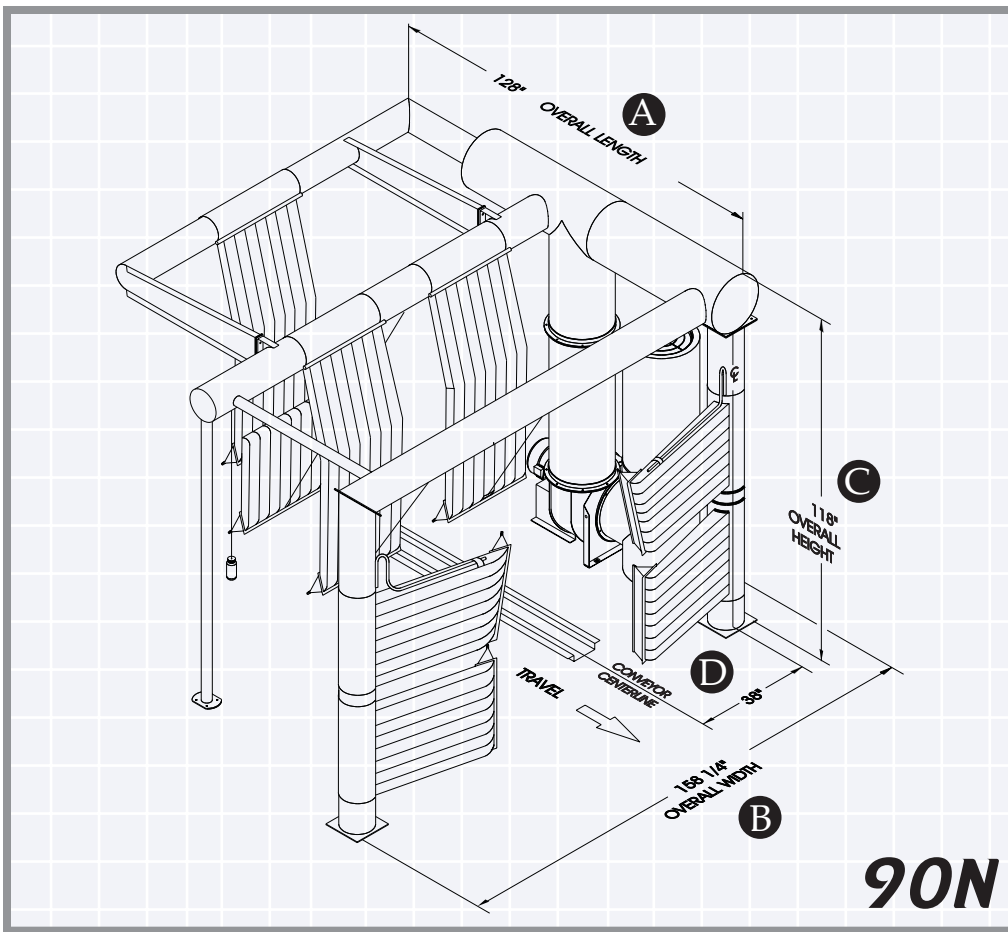

## EQUIPMENT

- A** OVERALL LENGTH  
128 in.
- B** OVERALL WIDTH  
158 1/4 in.
- C** OVERALL HEIGHT  
118 in.
- D** CONVEYOR CENTERLINE  
38 in.

## MOTORS

- 15-hp, 3600 RPM's
- 208-230 / 460 volts
- 1.15 service factor
- Frame: 254T
- 3 Phase
- Fan-cooled, totally enclosed

*NOTE: Wiring and controls to be provided by the purchaser. Additional motor specifications available upon request. Additional voltages available on special order.*

## EQUIPMENT OPTIONS

- Green, Red, Blue or Custom Bag Colors
- The Silencer Package™
- Vehicle Recognition System™ (VRS)
- Mist Eliminator™
- Tunnel Heater

Weight: 1280 lbs. (approximate)

## GENERAL DESCRIPTION

The Proto-Vest "Stripper"® was developed to perform as the carwash industry's most efficient and effective drying system. The Stripper's incomparable performance is ideal for carwash centers in need of a reliable dryer that can handle high volume and fast line speeds without sacrificing performance or quality. This system's seven Proto-Duck™ air delivery bags are specifically designed to gently follow a vehicle's contour with a feather light touch, to strip water from its surface.

Proto-Vest's blower/motor assembly is engineered for both maximum efficiency and cost effectiveness. As a result of the Stripper's patented nozzle air delivery systems and the bags close proximity to the vehicle surface, a 15-hp blower is all that is required to dry a vehicle.

Proto-Vest's stringent standards in material selection for our dryers results in extended equipment life and reduced maintenance. The 90N's blower assembly is manufactured from powder coated steel and is AMCA certified. Its plenum is made from 5052-H32 aluminum and its bags are produced from durable Proto-Duck™ material to resist corrosion and tearing.

## FEATURES / BENEFITS

### Patented Design:

Pressurized air flows through seven patented air delivery bags which strip water from the vehicle's horizontal and vertical surfaces. It dries the hood, roof, deck, windows and sides of the vehicle

### Low Maintenance:

Light maintenance and periodic cleaning is recommended to ensure peak performance.

### Line Speed Efficiency:

The Stripper dryer has proven to be the most efficient drying system made. With a 15-hp blower, the Stripper will give you approximately a 95% dry car at any line speed.

### Efficient design:

Designed to provide the driest car possible with an automatic drying system. The Stripper's patented nozzles gently glide over the vehicle's surfaces, literally stripping away the water.

## DECIBEL READINGS

With Silencer / Without Silencer	
(WS)	(WOS)
90N - (1) 15-hp dryer:	
WS: 10 ft=74.5 dBA;	WOS: 10 ft=82.9 dBA
WS: 20 ft=68.5 dBA;	WOS: 20 ft=76.9 dBA
WS: 30 ft=64.9 dBA;	WOS: 30 ft=73.4 dBA
WS: 40 ft=62.4 dBA;	WOS: 40 ft=70.9 dBA
WS: 50 ft=60.5 dBA;	WOS: 50 ft=69 dBA

(The above decibel readings are interpolated.)

## SERVICE / SUPPORT

Proto-Vest recognizes that support after the sale of equipment is critical to the success of our customers. Our company offers its customers access to a wide range of services including: field service technicians, factory direct aftermarket parts, and an engineering staff for custom designed applications.

### Proto-Vest Patents:

U.S.: 3,942,430; 4,161,801; 4,409,035; 4,418,442; 4,433,450; 4,445,251; 4,446,592; 4,589,160; 4,700,426; 5,027,714; 5,184,369; 5,187,881; 5,195,207; 5,280,665; 5,421,102; 5,553,346; 5,886,648; 5,901,461; 5,950,324; 5,960,564; 6,038,781; 6,176,024; 6,519,872; others pending.

Canada: 1,021,996; 1,111,328; 1,190,453; 1,201,040; 1,197,439; 1,219,195; 1,219,192; 1,219,194; 1,258,026; 1,219,193; 2,013,749; 2,071,568; 2,071,239; 2,071,388; others pending.

**Proto-Vest Inc.**

\*Specifications subject to change without notice.

\*\*If starting motor over 10-12 times an hour it may be more efficient to leave blower on.

Proto-Vest, Inc., 7400 N. Glen Harbor Blvd., Glendale, AZ 85307 • 800-521-8218 • 623-872-8300 • Fax 623-872-6150  
www.proto-vest.com

© Copyright 1998, Proto-Vest, Inc. All rights reserved.